

DESIGNED FOR WELD STUD DETECTION NEEDS

The VeriFast™ LVDT SYVR:

- ▶ is primarily designed for automatically fed stud weld applications
- ▶ has a **weld pin stroke of 50 mm** to accommodate most weld stud designs

Features & Benefits

- Available in CenterLine series 2, 3 and 4

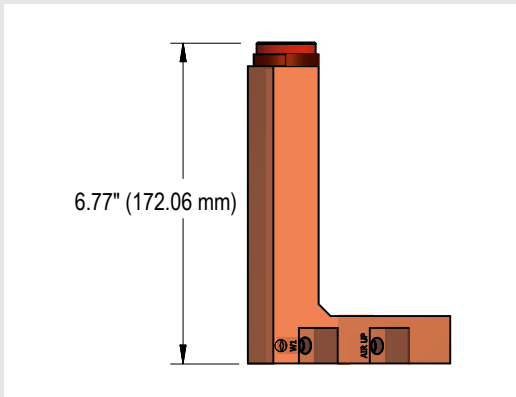

- Allows increased water flow for demanding applications
- Uses standard VeriFast™ LVDT heads and stud weld pins
- Uses standard signal conditioner calibrated for SYVR bodies



Dimensions

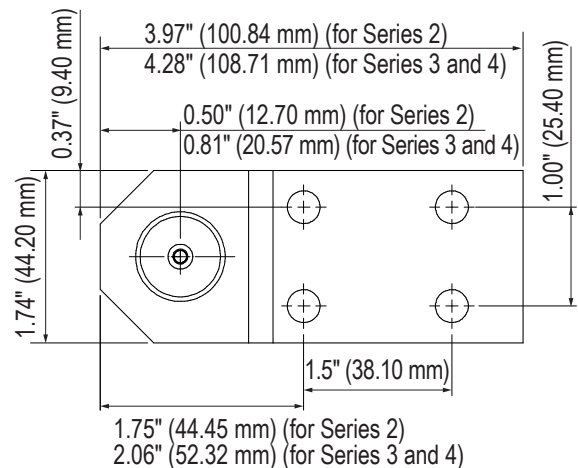

Contact CenterLine today for more information about our fastener sensing capabilities and visit our website at www.cntrline.com.

CENTERED ON SOLUTIONS

HEAD OFFICE:

CenterLine (Windsor) Ltd.
415 Morton Drive
Windsor, Ontario, Canada
N9J 3T8

Head Office
Sales
Service

TELEPHONE

519-734-8464
519-734-6560
519-734-0080

TOLL-FREE

800-820-6977
800-771-6172
800-268-8184

EMAIL

info@cntrline.com
sales@cntrline.com
service@cntrline.com