



FlexGun™ RA Application - Round Arms

Customer Information

Contact Name

Company

Phone

Email

End User

Program Name

Application Type

Robot Top
Pedestal LH

Gun Details

Equalizing RH
Non-Equalizing Rear
 Bottom

Electrode Details

Female Robot Type/Model
Male Robot Payload (kg)

Nose Type

A Dress Package
B Dress Package (kg)
Other - Specify

Transformer

AC
MFDC

Plant Voltage

Equalizing on the Gun
Equalizing on the Robot

Duty Cycle & Weld Schedule

Number of Welds / min.

Number of Long Strokes / min.
(Full gun opening)

Number of Short Strokes / min.
(Partial gun opening)

Max. Weld Force

Max. Weld Current

Weld Time (ms)

Total Squeeze (hold) Time (Weld,
Cool, Hold)

Comments:

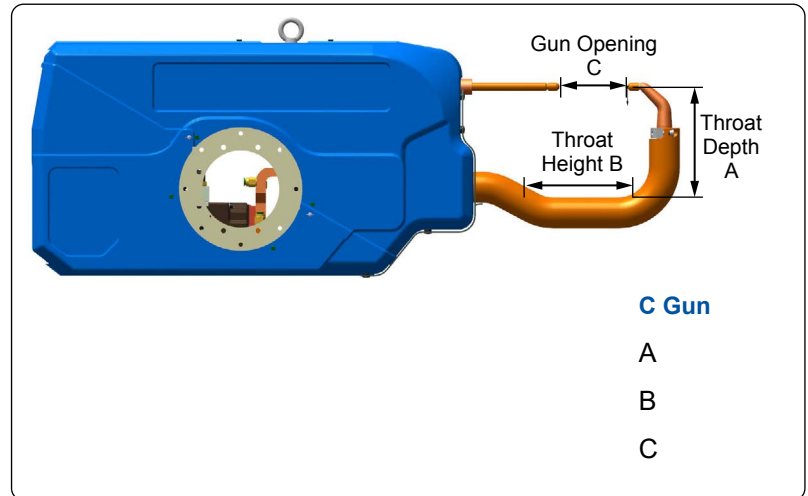
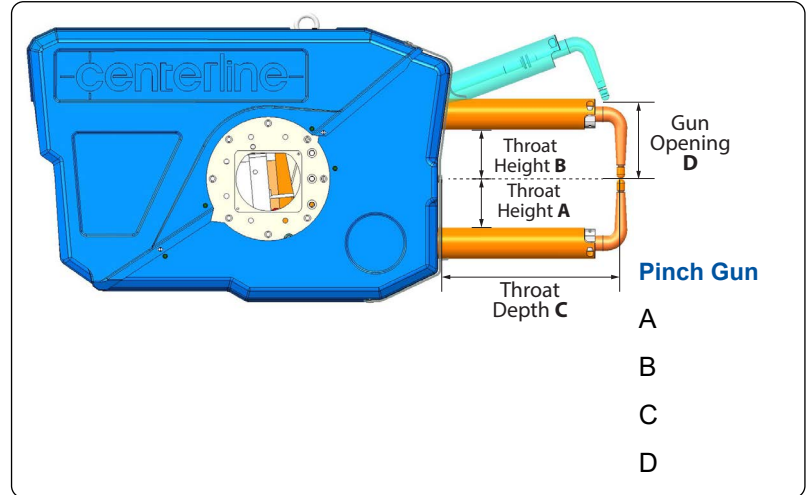

Water Hose Colour

Water In

Water Out

If not specified, CenterLine standard colours (Green In / Black Out) will be used.

Metal Specs/Type

Stackup

Port Quantity

Port Size

Hose Type

Metal Types

Note: Customer supplied or CenterLine weld schedule. If nothing is specified, CenterLine weld schedule will be used.